



Material no : **1SCBO712022**
 Model : **C-BHR 325L0Z**
 Customer : **Shoei**

Customer Approved

Hermetic compressor NON-CFC

100 V~ 50 / 60 Hz 1 Phase

(Sign / Sealed)

Dimension (mm)

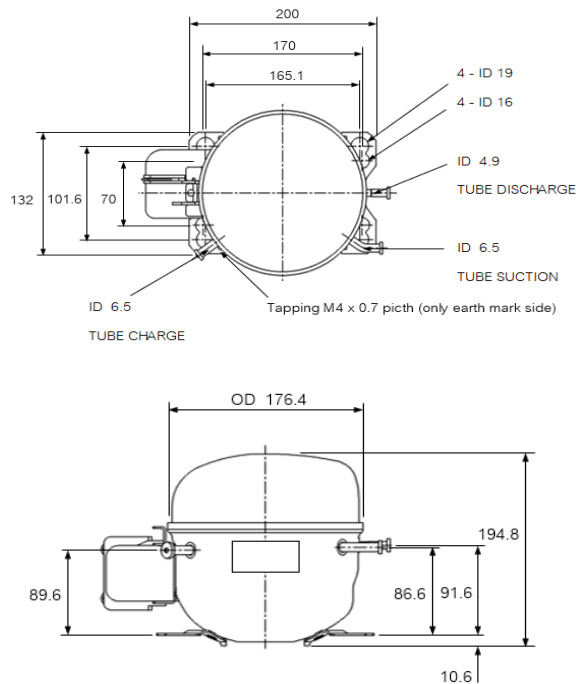

Performances data

Cooling capacity	± 8%	(Btu/h)	1009.4	1261.7
	± 8%	(Kcal/h)	254.6	318.2
	± 8%	(W)	296.0	370.0
Input power	± 8%	(W)	211.4	255.2
Input current	± 8%	(A)	-	-
COP		(W/W)	1.40	1.45
EER		(Btu/h.W)	4.77	4.94
		(Kcal/h.W)	1.20	1.25
Starting V. (at 7 kg/cm ² G)		(V)	85 max	
Noise (Distance 30 cm)		dB(A)	44 max	45 max
Rated voltage			100V/50Hz	100V/60Hz

Test condition

Evaporating temp.	(°C)	-23.3	(-10 °F)
Condensing temp.	(°C)	54.4	(130 °F)
Suction gas temp.	(°C)	32.2	(90 °F)
Liquid temp.	(°C)	32.2	(90 °F)
Ambient temp.	(°C)	32.2	(90 °F)

Application

Evaporating temp. range	(°C)	-40 ~ 10	(-40 ~ 50 °F)
Refrigerant		R-290	
Compressor cooling		Fan Cooling	
Voltage range	(V)	85 ~ 110	

Compressor and motor data

Design		Reciprocating 1-Cylinder	
Bore size ID	(mm)	24.0	
Stroke	(mm)	15.0	
Displacement	(cc/rev)	6.79	
Oil charge (Visc.32mm ² /s)	(cc)	250	
Motor type		1 Phase / 2 Pole / CSR	
Winding resistance at 25 °C (77 °F)			
Main coil ± 5 %	(ohm)	1.66	
Aux. coil ± 5 %	(ohm)	5.72	
Revolution	(rpm / Hz)	2900 / 50	3500 / 60
Weight (No oil / with oil)	(kg)	-	

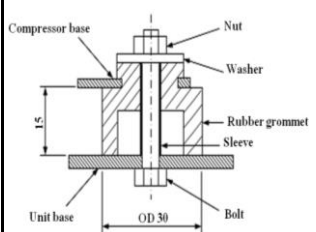

Mounting set		
Item	Code	Q'ty (EA)
Nut 6mm.	001	4
Bolt 6x35L	210	4
Washer OD20	108	4
Rubber grommet	501	4
Sleeve (L22.5)	501	4
Cover	505	1
Clip	504	1

Circuit diagram CSR

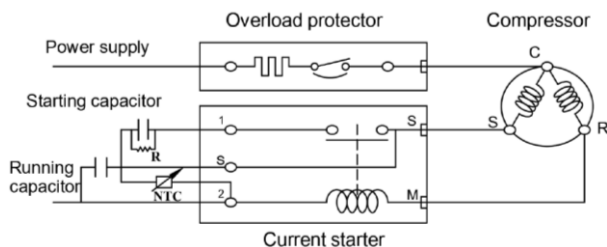

Electrical parts

Overload protector		External thermal over current type	
Type		-	
UT current / ST current	(A)	-	
Current Starter		KME682-25NTP	(3KME682-25NTPASY)
Pick up current max	(A)	9.60	
Drop out current max	(A)	8.40	
Starting capacitor	(μF / V)	125 / 160 with resistor (40CM524050)	
Running capacitor	(μF / V)	40 / 220 Shizuki (40CM524036)	

Issued by T. Thiipada Apr 10, 24

Quality Assurance Department / Kulthorn Premier Company Limited.

Certification Marks



Application Standard

[Compressor L.B.P / M.B.P / H.B.P Type]

When use compressor, confirm if the following standards are kept.

No	Item	Standard & Designation	Conditions - Remark
1	Refrigerant	R290	
2	Evaporating temp.	L.B.P -35 ~ -5 °C (-31~23 °F) M.B.P, H.B.P -15 ~ 10 °C (5~50 °F)	Except for the short period such as Pull-down etc.
3	Condensing temp.	60 °C (140 °F) max.	In stabilized at A/T 43 °C (110 °F)
		40-45 °C (104~113 °F)	In stabilized at A/T 30 °C (86 °F)
		Recommend temp.	At the peak in pull-down in A/T 43 °C (110 °F)
		68 °C (154 °F) max.	During the pull-down period at ambient temp. of 43 °C (110 °F)
4	Compression ratio	L.B.P. : 14.5 max. M.B.P., H.B.P : 12.0 max .	Hi-side / Lo-side pressure (abs) Except very short period as pull-down.
5	Motor winding temp.	Usual : 115 °C (239 °F) max. Max. : 130 °C (266 °F) max.	In stabilized at A/T 30 °C (86 °F) In stabilized at A/T 43 °C (110 °F) with ± 10% x rated voltage.
6	Shell bottom temp. (low side)	Max. : 105 °C (221 °F) max.	In stabilized at A/T 43 °C (110 °F) with ± 10% x rated voltage.
7	Discharge gas temp.	Usual : 105 °C (221 °F) max. Max. : 121 °C (250 °F) max.	In stabilized at A/T 30 °C (86 °F) In stabilized at A/T 43 °C (110 °F) with ± 10% x rated voltage.
* Measured on the pipe at 5 cm (2 inches) away from shell.			
8	Suction gas temp. (Super Heat)	5 °C (41 °F) min.	Follow strictly items 5, 6 and 7, on the pipe At 20~30 cm (8~12 inches) away from shell.
9	Voltage range	-15% ~ 10% x rating	At the terminals of compressor
10	Refrigerant Charge	Minimal	Minimize meeting cooling performance, startability, temperature limits, pressure limits and the like.
11	Oil Charge	Designated quantity ± 10 cc.	Charge in designated oil Acid number 0.02 KOH/g max. Colour 1.0 Max (ASTM Std.) Moisture 10 ppm max. Residual gas. 0.2 Vol% max.
12	Moisture	100 ppm max.	Special dryer is needed (For instance XH-7 or XH-9)
13	Non-condensable gas	Total : 1% (Vol) max. Oxygen : 0.01% (Vol) max.	Recommended Level of evacuation should be less than 1.01 Kpa at 24 hours after evacuation completed.
14	Dust and Dirt	To be determinaid	Need to survey user capability.
15	Pressure rise at abnormal situation	3.43 Mpa max.	Even in case of condenser fan-blocked.

Application Standard

[Compressor L.B.P / M.B.P / H.B.P Type]

When use compressor, confirm if the following standards are kept.

No	Item	Standard & Designation	Conditions - Remark
16	On-Off period	6 times / hour (Recommended)	Recommended to start up at balanced Hi-Low pressure in 5 minutes after standstill.
17	Oil return in comp.	90% min. the charge	Measure in hot condition after designated appliance test.
18	Strain in piping	0.34 Mpa. max. (34.32 N/mm ² max.) 0.12 Mpa. max. (12.26 N/mm ² max.)	At time of start-up and disconnection. in operation
19	Degree of tilt	On running, compressor shall not be tilted more than 5 degrees in all direction.	
20	Electical parts	Designated parts	Confirm its suitability with unit test. Keep to designated temperature range.
21	Mounting parts	Designated parts or equivalents	Confirm its suitability with unit transportation test.

NOTE

A. Remarks on Compressor

- (1). In principle, the compressor charged with lubricating oil must be used within about 6 month from production date.
- (2). Usual the compressor by removing the plug at the tube end and check to see if gas comes out from the compressor. If no detected. The compressor must not be used.
- (3). Do not leave the compressor with its pinch plug open for more than about 15 minutes.
- (4). Never run the compressor with any air other than the refrigerant.
- (5). Never run the compressor without refrigerant properly filled inside.
- (6). Never run when the compressor has vacuum.
- (7). Never run the compressor without lubricating oil properly field inside.
- (8). Never run the compressor without refrigeration systems properly completed.
- (9). A dropped compressor must not be used.

B. Remarks on Refrigeration Systems.

- (1). To avoid any contamination on the refrigerator assembly line, a dedicated charging station (refrigerant or oil) must be used.
- (2). All materials used in the process must be compatible with (R134a & R1234yf).
- (3). The system components must have a degree of cleanliness better than that of CFC12 system. Especially residue of chlorinated impurity shall not be allowed.
- (4). The maximum moisture content in refrigerant cycle should be 150 mg.
- (5). Special dryer is needed when using (R134a & R1234yf). (for instance XH-7 or XH-9 from Union Carbide) Usually a 20% larger dryer is recommended.
- (6). Special leak-detectors have to be used.

C. Others (The ambient condition to be observed)

- (1). 43 °C (110 °F) or less.
- (2). Keep well ventilated around the compressors.
- (3). Keep well dried around the compressors.
- (4). Avoid operation the compressor when a corrosive gas or an inflammable gas is present.
- (5). Do not operate the compressor in any vibration consonant.
- (6). Certain materials cam degrade the characteristics of Starting relay device.
 - (6.1) Starting relay device should not be exposed to sulphur (S) or chlorine (cl) containing gases, and must be kept away from materials that can generate them. In particular, avoid the use of polyvinyl chloride (PVC) insulation in contact with starting relay terminals.
 - (6.2) Starting relay device should not be exposed to oils of any kind.